

Helping Customers Innovate, Improve & Grow



XR-A (HC49) Series

Description

Vectron International's XR-A (HC49) Series crystals provide a high reliability design in a rugged mount. These precision crystals offer excellent performance characteristics and tight stabilities in a wide range of frequencies. Outstanding performance in a cost effective industry standard package make this an ideal crystal for a wide range of applications.

Features

- Cost Effective-Volume Production Available
- Industry Standard Holder (smaller can heights available)
- AT-Cut Fundamental and OT Modes (3rd, 5th, 7th)
- Resistance Weld (HC49/U)
- Tight Stabilities and Tolerances, Excellent Aging
- Robust Rugged Design for harsh environments
- Surface Mount Lead Forming options available
- Swept Quartz & Hi-Rel Screening Options Available
- High Temperature Options to +200°C
- MIL-PRF-3098 (CR64/U, CR69/U) equivalent

Applications

- Telecommunications
- Military & Defense
- Base Station
- Medical-Test and Measurement Instrumentation
- Precision Oscillators (TCXO, VCXO, OCXO)

Note: HC43 (XR-B series for best precision/stability-Cold Weld)

Standard Physical Specifications

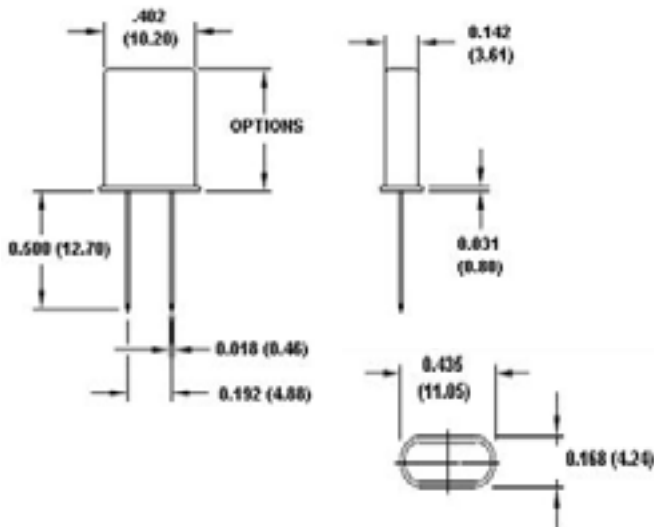

HEIGHT CODE OPTION	PACKAGE EXAMPLES	
	XR-A SERIES	
	inches	mm
1	0.530	13.46
2	0.440	11.17

*Nominal dimensions specified in inches and millimeters (mm).
Specification subject to change without notice.*

SURFACE MOUNT APPLICATIONS:

Special lead forming is available for surface mount applications



Typical Electrical Performance Characteristics

HC49/U AT-CUT VARIETIES		
Performance Characteristic	Symbol	Typical Performance Specifications
Frequency Range	F_o	2.2 MHz to 210 MHz
Operating Temperature Range		-55°C to +125°C (high temperature up to +200°C available)
Frequency Stability over Operating Temp Range	F_T	+/- 5 ppm to +/- 50 ppm (mode, frequency and operating temp range dependent)
Frequency Calibration Tolerance +25°C	F_R-F_L	+/- 10 ppm typical (+/- 2 ppm available)
Equivalent Series Resistance	R (ESR)	10 ohms to 360 ohms (mode and frequency dependent)
Shunt Capacitance	C_o	2.5 pF - 4 pF typical
Motional Capacitance	C_1	0.1 fF - 30 fF (mode and frequency dependent)
Load Capacitance	C_L	series to 32 pF (customer specified load)
Drive Level	DL	100 uW (50 uW to 5 mW)
Aging per year after first 30 days		< 3 ppm (< 1ppm available)

MODE	FREQUENCY RANGE (MHz)	*ESR Typical (ohms)	* C_1 Typical (fF)
Fund.	2.2 - 30 MHz	25-360	5 - 25
3 rd	10 - 90 MHz	40	1 -2.5
5 th	20 - 150 MHz	75	0.70
7 th	70 - 210 MHz	120	0.35

*ESR and C1 values are dependent upon the specified frequency and mode of vibration.

PHASE NOISE @ 100 Hz OFFSET (dBc/Hz)		
Mode - Cut	Frequency Range	Phase Noise
Fundamental-AT	7 MHz -to 30 MHz	-80 to -115
3 rd OT - AT	17 MHz - 105 MHz	-80 to -135
5 th OT - AT	40 MHz - 175 MHz	-90 to -135
7 th OT - AT	70 MHz - 225 MHz	-90 to -125

Phase Noise performance is mode and frequency dependent

Vectron International designs and manufactures HC49 series resistance weld crystals for a wide variety of commercial and high reliability applications. *Our proven processes yield excellent aging and low perturbations.* We have tight controls over series resistance, motional capacitance, temperature characteristics and other parameters critical to your application. We primarily build to customer specifications but we've optimized designs on all frequencies that are commonly used in telecommunications. Tighter performance requirements than those shown above may be available.

Please feel free to contact us with your questions. We are here to assist you with selecting the best performing and most cost effective crystal for your application.

Typical Environmental Specifications

TEST DESCRIPTION	SPECIFICATION REFERENCE
SHOCK	MIL-STD-202, Method 213, Cond. C (100g, 6ms, Half-Sine)
VIBRATION	MIL-STD-202, Method 201/204 (Random-Sine, 20g)
TEMPERATURE CYCLE	MIL-STD-883, Method 1010 (-55°C/+125°C), 10 cycles
THERMAL SHOCK	MIL-STD-202, Method 107
MOISTURE RESISTANCE	MIL-STD-202, Method 106
SALT ATMOSPHERE	MIL-STD-202, Method 101
ACCELERATION	MIL-STD-883, Method 2001, Condition A (5,000g)
SOLDERABILITY	MIL-STD-202, Method 208 (ANSI-EIA-J-STD-002)
TERMINAL STRENGTH	MIL-STD-202, Method 211 (2lbs)
PIND	MIL-STD-883, Method 2020, Condition A or B (20g, 10g)
FINE LEAK	MIL-STD-202, Method 112, Condition C-IIIc (1x10 ⁻⁸ atm/cc ²)
GROSS LEAK	MIL-STD-202, Method 112, Condition D
RESISTANCE TO SOLVENTS	MIL-STD-202, Method 215
RESISTANCE TO SOLDERING HEAT	MIL-STD-202, Method 210, Condition K
HIGH TEMPERATURE STORAGE	MIL-STD-883, Method 1008, Condition C (+125°C, 168 hours)
LOW TEMPERATURE STORAGE	MIL-PRF-3098

Vectron is uniquely equipped to handle all of your special test requirements. All environmental and qualification related tests are performed in house. We've demonstrated compliance and the ability to test to the requirements of all governing industry and military crystal specifications (past and present).

Some of which include;

- MIL-PRF-3098
- MIL-C-49468
- MIL-C-3098
- TOR-2006 (8583)-5236
- EEE-INST-002
- MIL-PRF-55310
- MIL-STD-202
- MIL-STD-883
- OTHERS

PART NUMBER ORDERING INFORMATION

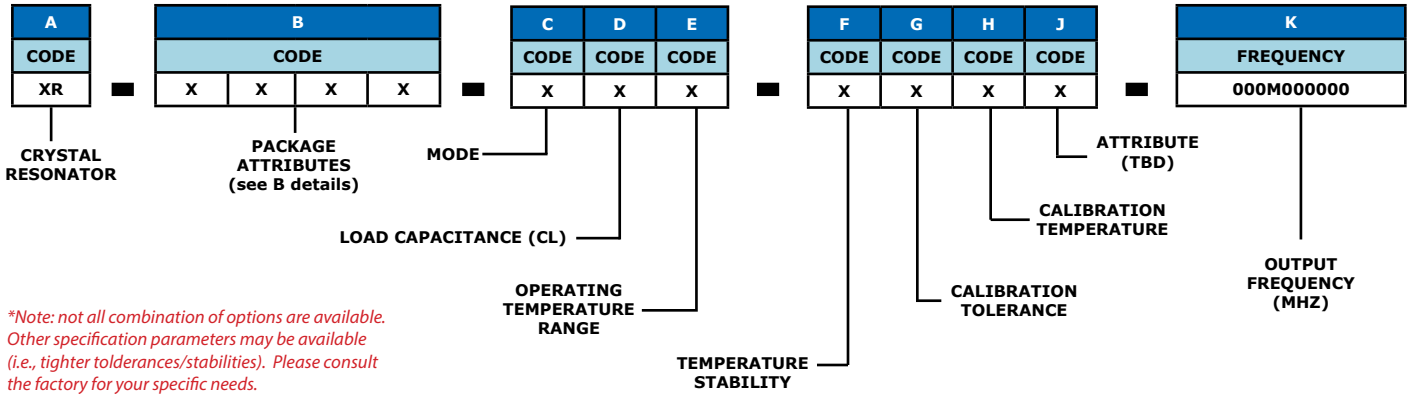

PART NUMBER CODES (attribute details)

B							
X		X		X		X	
CODE	PACKAGE TYPE	CODE	PACKAGE HEIGHT (A)	CODE	SEAL METHOD	CODE	LEAD STYLE
A	HC49	1	.530 (13.46)	1	RW	1	STANDARD
		2	.440 (11.17)			2	LEAD FORM (SMT)

C	
CODE	MODE
1	Fund
3	3 rd OT
5	5 th OT
7	7 th OT
9	9 th OT

E	
CODE	OPERATING TEMPERATURE RANGE
A	-55°C to +85°C
B	-55°C to +105°C
C	-55°C to +125°C
D	-40°C to +70°C
E	-40°C to +85°C
F	-40°C to +105°C
G	-30°C to +80°C
H	-30°C to +85°C
J	-20°C to +70°C
K	-10°C to +60°C
M	-10°C to +75°C
N	-5°C to +70°C
P	0°C to +50°C
R	0°C to +55°C
S	0°C to +60°C
T	0°C to +70°C
U	0°C to +85°C
V	+10°C to +40°C
W	-10°C to +70°C
Y	-55°C to +185°C
Z	-20°C to +180°C
1	0°C to +150°C
2	0°C to +200°C
9	Custom

F	
CODE	FREQUENCY STABILITY OVER TEMPERATURE
A	+/- 5 ppm
B	+/- 10 ppm
C	+/- 12 ppm
D	+/- 15 ppm
E	+/- 20 ppm
F	+/- 25 ppm
G	+/- 30 ppm
H	+/- 32 ppm
J	+/- 40 ppm
K	+/- 50 ppm
M	+/- 60 ppm
N	+/- 75 ppm
P	+/- 80 ppm
R	+/- 90 ppm
S	+/- 100 ppm
T	+/- 130 ppm
U	+/- 150 ppm
V	+/- 200 ppm
W	+/- 250 ppm
Y	+/- 300 ppm
Z	Custom

G	
CODE	FREQUENCY CALIBRATION TOLERANCE
A	+/- 5 ppm
B	+/- 10 ppm
C	+/- 12 ppm
D	+/- 15 ppm
E	+/- 20 ppm
F	+/- 25 ppm
G	+/- 30 ppm
H	+/- 32 ppm
J	+/- 40 ppm
K	+/- 50 ppm
M	+/- 60 ppm
N	+/- 75 ppm
P	+/- 80 ppm
R	+/- 90 ppm
S	+/- 100 ppm
T	+/- 130 ppm
U	+/- 150 ppm
V	+/- 200 ppm
W	+/- 250 ppm
Y	+/- 300 ppm
Z	Custom

H	
CODE	FREQUENCY CALIBRATION TEMPERATURE
A	+25°C
B	+50°C
C	+55°C
D	+60°C
E	+65°C
F	+70°C
G	+75°C
H	+80°C
J	+85°C
K	+90°C
M	+95°C
N	+100°C
P	+105°C
R	+110°C
S	+115°C
T	+120°C
U	+125°C
Z	Custom

J	
CODE	TBD
A	TBD
B	TBD
C	TBD
D	TBD
E	TBD
F	TBD
G	TBD
H	TBD
J	TBD
K	TBD
M	TBD
N	TBD
P	TBD
R	TBD
S	TBD
T	TBD
U	TBD
Z	Custom

CALIBRATION TEMPERATURE IS ALWAYS +25°C UNLESS OTHERWISE SPECIFIED

Additional Technical Information

Typical Wave Solder Reflow Profile (Sn-Pb)

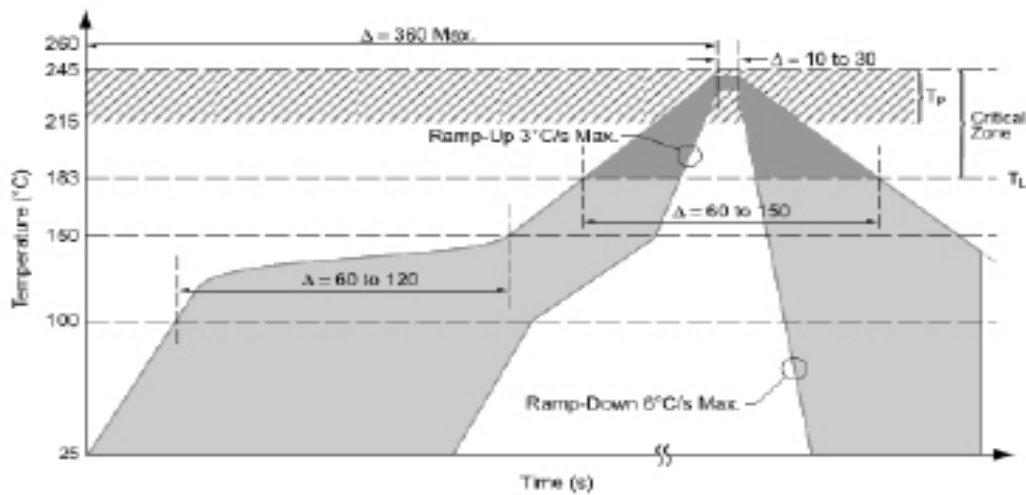

Diagrams of Series and Parallel Resonant Circuits

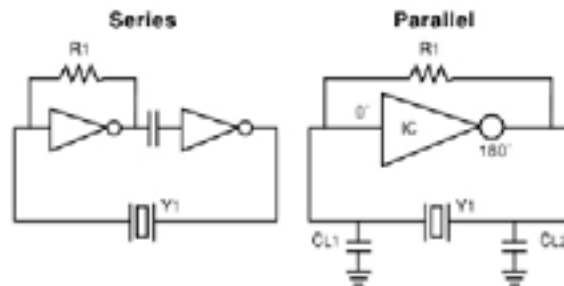

Equivalent Circuit of a Crystal Resonator

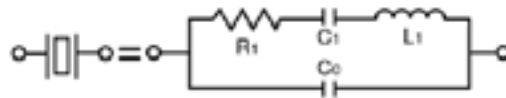

For Additional Information, Please Contact

USA:

Vectron International
4914 Gray Road
Cincinnati, OH 45232
Tel: 1.513.542.5555
Fax: 1.513.542.5146
Tel: 1.888.328.7661

Europe:

Vectron International
Landstrasse, D-74924
Neckarbischofsheim, Germany
Tel: +49 (0) 3328.4784.17
Fax: +49 (0) 3328.4784.30

Asia:

Vectron International
1F-2F, No 8 Workshop, No 308 Fenju Road
WaiGaoQiao Free Trade Zone
Pudong, Shanghai, China 200131
Tel: 86.21.5048.0777
Fax: 86.21.5048.1881

Disclaimer

Vectron International reserves the right to make changes to the product(s) and or information contained herein without notice. No liability is assumed as a result of their use or application. No rights under any patent accompany the sale of any such product(s) or information.

Rev: 12/2009