

VI TELEFILTER**Filter specification****TFS 70H13****1/5****1. Measurement condition :**

Ambient temperature T_A : 25 °C.
 Input power level: 0 dBm.
 Terminating impedances in f_C : for input: 50 Ω | 0 pF.
 for output: 50 Ω | 0 pF.

2. Characteristics :

Remark:

Reference level for the relative attenuation a_{rel} of the **TFS 70H13** is the minimum of the pass band attenuation a_{min} . The minimum of the pass band attenuation a_{min} is defined as the insertion loss a_e . The reference frequency f_C is the arithmetic mean value of the upper and lower frequencies at the 20 dB filter attenuation level relative to the insertion loss a_e . The temperature coefficient of frequency T_{Cf} is valid both for the reference frequency f_C and the frequency response of the filter in the operating temperature range. The frequency shift of the filter in the operating temperature range is not included in the production tolerance scheme.

Data		typ. value	tolerance / limit
Insertion loss (Reference level)	a_e	22,7 dB	max. 24 dB
Centre frequency at ambient temperature (f_{CTA})	f_C	70,0 MHz	70,0 \pm 0,1 MHz
Pass band :	PB		$f_C \dots f_C \pm 4,0$ MHz
Amplitude ripple in : $f_C \dots f_C \pm 3,6$ MHz		0,45 dB	max. 0,8 dB
Bandwidth at ambient temperature T_A :	BW		
1 dB		7,83 MHz	min. 7,6 MHz
3 dB		8,39 MHz	min. 8,0 MHz
5 dB		8,70 MHz	
10 dB		9,20 MHz	
20 dB		9,78 MHz	
30 dB		10,16 MHz	
40 dB		10,43 MHz	max. 10,6 MHz
50 dB		10,62 MHz	
Relative attenuation	a_{rel}		
$f_C \dots f_C \pm 3,6$ MHz		-	max. 0,8 dB
$f_C \pm 3,6$ MHz ... $f_C \pm 3,8$ MHz		-	max. 1 dB
$f_C \pm 3,8$ MHz ... $f_C \pm 4,0$ MHz		-	max. 3 dB
$f_C \pm 5,3$ MHz ... $f_C \pm 6$ MHz		45 dB	min. 40 dB
$f_C \pm 6$ MHz ... $f_C \pm 15$ MHz		50 dB	min. 45 dB
$f_C \pm 15$ MHz ... $f_C \pm 50$ MHz		55...60 dB	min. 50 dB
Group delay (mean value in PB):-		1,83 μ s	max. 2,5 μ s
Group delay ripple in PB (p-p):		40 ns	max. 60 ns
Deviation from linear phase in PB :		2,4 deg	max. 4 deg
Triple transit attenuation compared to main signal		54 dB	
Crosstalk		60 dB	
Temperature coefficient of frequency (T_{Cf}) :		-87 ppm/K	
Frequency deviation of f_C over temperature :		$\Delta f_C(\text{Hz}) = T_{Cf}(\text{ppm/K}) \times (T - T_o) \times f_{CTA}(\text{MHz})$	
Operating temperature range		- 25 °C ... + 80 °C	
Storage temperature range		- 40 °C ... + 85 °C	

Generated: W. Dunzow

Checked / approved: Dr. Bert Wall

VI TELEFILTER**Potsdamer Straße 18****D 14 513 TELTOW / Germany****Tel: (+49) 3328 4784-0 / Fax: (+49) 3328 4784-30****E-Mail: tft@telefilter.com**

VI TELEFILTER reserves the right to make changes to the product(s) and/or information contained herein without notice. No liability is assumed as a result of their use or application. No rights under any patent accompany the sale of any such product(s) or information

3. Construction and pin connection : (All dimensions in mm)

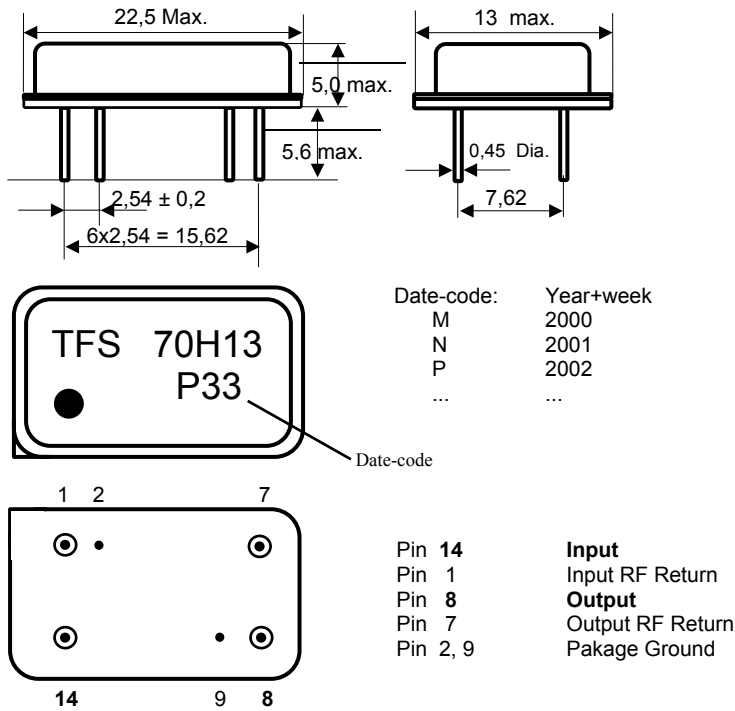

4. 50 Ω matching network (please refer to the application note for further details) :

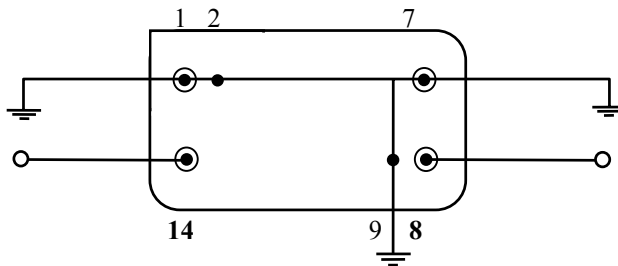

5. Stability characteristics :

After the following tests the filter shall meet the whole specification:

1. Shock: 500g, 18 ms, half sine wave, 3 shocks each plane;
DIN IEC 68 T2 - 27
2. Vibration: 10 Hz to 500 Hz, 0,35 mm or 5g respectively, 1 octave per min, 10 cycles per plan, 3 plans;
DIN IEC 68 T2 - 6
3. Change of temperature: -55 °C to 125°C / 30 min. each / 10 cycles
DIN IEC 68 part 2 – 14 Test N
4. Resistance to solder heat (reflow): reflow possible: twice max.;
for temperature conditions, please refer to the attached "Air reflow temperature conditions"
on page 4;

6. Air reflow temperature conditions :

1st and 2nd air reflow profile

Name:	pre-heating periods	main-heating periods	peak temperature
Temperature:	150 °C - 170 °C	over 200 °C	255 °C ± 5 °C
Time:	60 sec. - 90 sec.	20 sec. - 25 sec.	

Air reflow profile

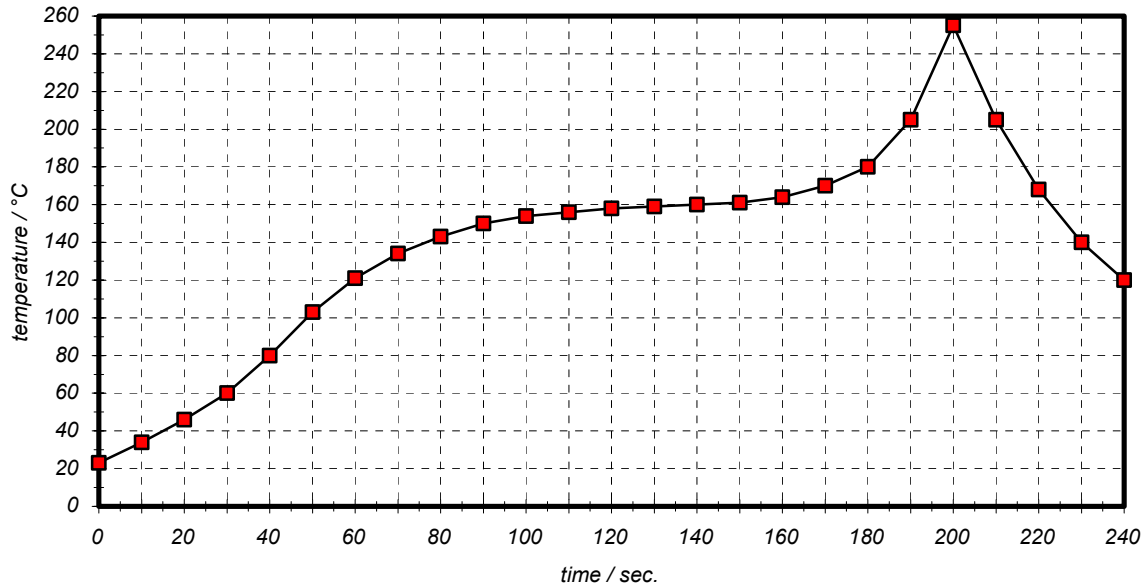

Table for temperature vs. time during the air reflow process

Tolerance of temperatures: ± 5 °C

time / sec.	temperature / °C	time / sec.	temperature / °C
0	23	140	160
10	34	150	161
20	46	160	164
30	60	170	170
40	80	180	180
50	103	190	205
60	121	195	230
70	134	200	255
80	143	205	230
90	150	210	205
100	154	215	180
110	156	220	165
120	158	230	140
130	159	240	120

VI TELEFILTER

Potsdamer Straße 18

D 14 513 TELTOW / Germany

Tel: (+49) 3328 4784-0 / Fax: (+49) 3328 4784-30

E-Mail: tft@telefilter.com

VI TELEFILTER reserves the right to make changes to the product(s) and/or information contained herein without notice. No liability is assumed as a result of their use or application. No rights under any patent accompany the sale of any such product(s) or information

VI TELEFILTER**Filter specification****TFS 70H13****5/5**

History

Version	Reason of changes	Name	Date
1.0	generate preliminary specification .	Dunzow W.	22.11.2001
1.1	generate filter specification.	Dunzow W.	24.06.2002

VI TELEFILTER
Potsdamer Straße 18
D 14 513 TELTOW / Germany
Tel: (+49) 3328 4784-0 / Fax: (+49) 3328 4784-30
E-Mail: tft@telefilter.com

VI TELEFILTER reserves the right to make changes to the product(s) and/or information contained herein without notice. No liability is assumed as a result of their use or application. No rights under any patent accompany the sale of any such product(s) or information