

**VI TELEFILTER****Filter specification****TFS 70H23****1/5****1. Measurement condition :**

Ambient temperature $T_A$ :	23 °C
Input power level:	0 dBm.
Terminating impedances at $f_C$ *) :	for input: 217 $\Omega$   - 17,77 pF.
	for output: 343 $\Omega$   - 14,66 pF.
Source impedance:	50 $\Omega$
Load impedance:	50 $\Omega$

**2. Characteristics :**

Remark: Reference level for the relative attenuation  $a_{rel}$  of the **TFS 70H23** is the minimum of the pass band attenuation  $a_{min}$ . The minimum of the pass band attenuation  $a_{min}$  is defined as the insertion loss  $a_e$ . The reference frequency  $f_C$  is the arithmetic mean value of the upper and lower frequencies at the 3 dB filter attenuation level relative to the insertion loss  $a_e$ . The temperature coefficient of frequency  $Tc_f$  is valid both for the reference frequency  $f_C$  and the frequency response of the filter in the operating temperature range. The frequency shift of the filter in the operating temperature range is not included in the production tolerance scheme

Data		typical values	tolerance / limit
<b>Insertion loss</b> (Reference level)	$a_e$	18 dB	max. 23 dB
<b>Centre frequency</b> $f_C$ at ambient temperature $T_A$ ( $f_{CAT}$ )		70,01 MHz	$70 \pm 0,07$ MHz
<b>Pass band</b> at ambient temperature $T_A$ :	<b>PB</b>		$f_C - 0,365$ MHz ... $f_C + 0,375$ MHz
<b>Amplitude ripple (p-p) in :</b>	$f_C \dots f_C \pm 0,2$ MHz	0,25 dB	-
<b>Bandwidth</b> at ambient temperature:			
0,5 dB		0,52 MHz	-
1 dB		0,65 MHz	min. 0,58 MHz
3 dB		0,87 MHz	min. 0,75 MHz
10 dB		1,22 MHz	-
20 dB		1,47 MHz	-
40 dB		1,78 MHz	max. 2,00 MHz
50 dB		1,88 MHz	-
60 dB		2,00 MHz	-
<b>Relative attenuation</b>	$a_{rel}$		
$f_C$ ... $f_C \pm 0,29$ MHz		0,7 dB	max. 1 dB
$f_C \pm 0,29$ MHz ... $f_C \pm 0,375$ MHz		1,8 dB	max. 3 dB
$f_C \pm 1$ MHz ... $f_C \pm 2$ MHz		50 dB	min. 40 dB
$f_C \pm 2$ MHz ... $f_C \pm 7$ MHz		47...50 dB	min. 45 dB
$f_C - 65$ MHz ... $f_C - 7$ MHz		70 dB	min. 50 dB
$f_C + 7$ MHz ... $f_C + 35$ MHz		55...65 dB	min. 50 dB
<b>Group delay ( mean value in PB ) :</b>		3,46 $\mu$ s	max. 4 $\mu$ s
<b>Group delay ripple in PB (p-p) :</b>		120 ns	max. 250 ns
<b>Phase ripple in PB (p-p) :</b>		1,1...1,3° ( r.m.s. 0,6° )	max. 4 deg
<b>Triple transit attenuation compared to main signal</b>		45 dB	-
<b>Crosstalk</b>		60 dB	-
<b>Frequency inversion temperature :</b>	$T_o$	20...40 °C	-
<b>Temperature coefficient of frequency :</b>	$Tc_f$	-0,04 ppm/K <sup>2</sup>	-
<b>Frequency deviation of <math>f_C</math> over temperature : **)</b>		$\Delta f_C(\text{Hz}) = Tc_f(\text{ppm/K}) \times (T - T_o)^2 \times f_{T_o}(\text{MHz})$	-
<b>Operating temperature range</b>		-	- 25 °C ... + 80 °C
<b>Storage temperature range</b>		-	- 40 °C ... + 85 °C

\*) The terminating impedances depend on parasitics and q-values of matching elements and the board used, and are to be understood as reference values only. Should there be additional questions do not hesitate to ask for an application note or contact our design team.

\*\*)  $f_{T_o}$  is frequency at frequency inversion temperature ( $T_o$ )

**Generated:** Dunzow W.

**Checked/Approved:** Dr. Wall

**VI TELEFILTER****Potsdamer Straße 18****D 14 513 TELTOW / Germany****Tel: (+49) 3328 4784-0 / Fax: (+49) 3328 4784-30****E-Mail: [tft@telefilter.com](mailto:tft@telefilter.com)**

VI TELEFILTER reserves the right to make changes to the product(s) and/or information contained herein without notice. No liability is assumed as a result of their use or application. No rights under any patent accompany the sale of any such product(s) or information.

**3. Construction and pin connection :**

pin grid 2,54 mm

(All dimensions in mm)

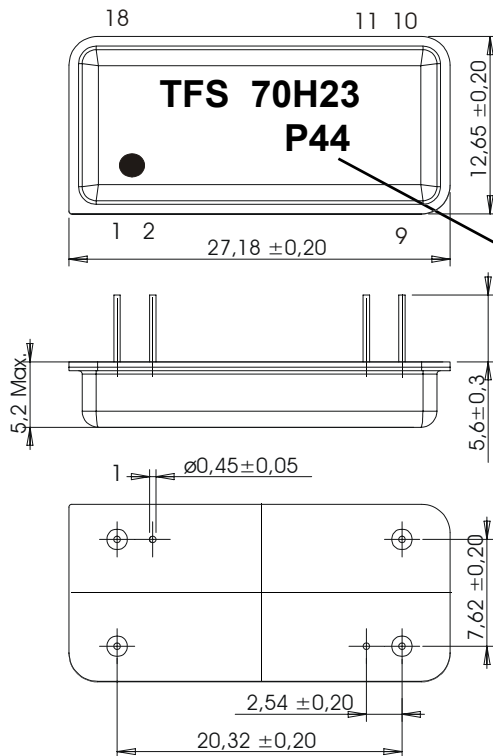

Date-code:	Year+week
M	2000
N	2001
P	2002
...	...

Date-code

Pin 18	<b>Input</b>
Pin 1	Input RF Return
Pin 10	<b>Output</b>
Pin 9	Output RF Return
Pin 2, 11	Package Ground

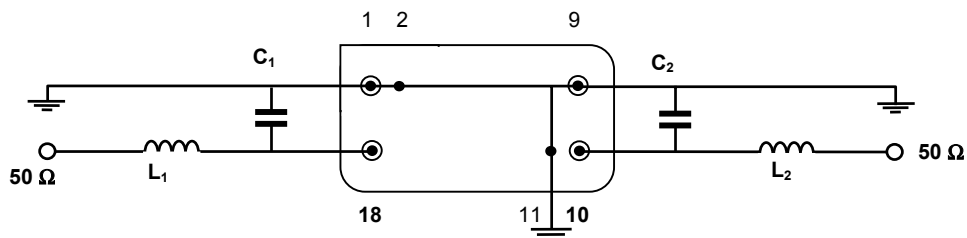
**4. 50 Ω matching networks ( for details refer to application note ) :****VI TELEFILTER**

Potsdamer Straße 18

D 14 513 TELTOW / Germany

Tel: (+49) 3328 4784-0 / Fax: (+49) 3328 4784-30

E-Mail: [tft@telefilter.com](mailto:tft@telefilter.com)

VI TELEFILTER reserves the right to make changes to the product(s) and/or information contained herein without notice. No liability is assumed as a result of their use or application. No rights under any patent accompany the sale of any such product(s) or information.

**5. Stability characteristics :**

After the following tests the filter shall meet the whole specification:

1. Shock: 500g, 18 ms, half sine wave, 3 shocks each plane;  
DIN IEC 68 T2 - 27
2. Vibration: 10 Hz to 500 Hz, 0,35 mm or 5g respectively, 1 octave per min, 10 cycles per plan, 3 plans;  
DIN IEC 68 T2 - 6
3. Change of temperature -55 °C to 125°C / 30 min. each / 10 cycles  
DIN IEC 68 part 2 – 14 Test N
4. Resistance to solder heat (reflow): reflow possible: twice max.;  
for temperature conditions refer to the attached "Air reflow temperature conditions" on page 4;

---

**VI TELEFILTER****Potsdamer Straße 18****D 14 513 TELTOW / Germany****Tel: (+49) 3328 4784-0 / Fax: (+49) 3328 4784-30****E-Mail: [tft@telefilter.com](mailto:tft@telefilter.com)**

---

VI TELEFILTER reserves the right to make changes to the product(s) and/or information contained herein without notice. No liability is assumed as a result of their use or application. No rights under any patent accompany the sale of any such product(s) or information.

**6. Air reflow temperature conditions :**

1st and 2nd air reflow profile

<b>Name:</b>	pre-heating periods	main-heating periods	peak temperature
<b>Temperature:</b>	150 °C - 170 °C	over 200 °C	255 °C ± 5 °C
<b>Time:</b>	60 sec. - 90 sec.	20 sec. - 25 sec.	

**Air reflow profile**

Table for temperature vs. time during the air reflow process

Tolerance of temperatures: ± 5 °C

time / sec.	temperature / °C	time / sec.	temperature / °C
0	23	140	160
10	34	150	161
20	46	160	164
30	60	170	170
40	80	180	180
50	103	190	205
60	121	195	230
70	134	200	255
80	143	205	230
90	150	210	205
100	154	215	180
110	156	220	165
120	158	230	140
130	159	240	120

**VI TELEFILTER**

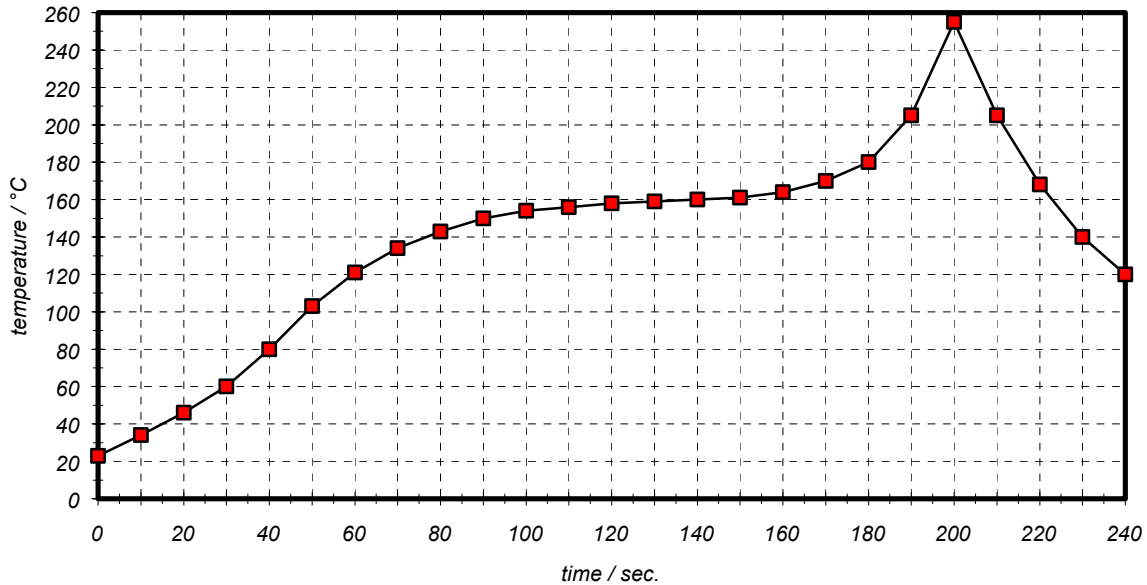
Potsdamer Straße 18

D 14 513 TELTOW / Germany

Tel: (+49) 3328 4784-0 / Fax: (+49) 3328 4784-30

E-Mail: [tft@telefilter.com](mailto:tft@telefilter.com)

VI TELEFILTER reserves the right to make changes to the product(s) and/or information contained herein without notice. No liability is assumed as a result of their use or application. No rights under any patent accompany the sale of any such product(s) or information.

**7. History**

<b>Version</b>	<b>Reason of changes</b>	<b>Name</b>	<b>Date</b>
1.0	- generate development specification.	Dunzow W.	10.12.2001
1.1	- generate filter specification.	Dunzow W.	26.06.2002

---

**VI TELEFILTER****Potsdamer Straße 18****D 14 513 TELTOW / Germany****Tel: (+49) 3328 4784-0 / Fax: (+49) 3328 4784-30****E-Mail: [tft@telefilter.com](mailto:tft@telefilter.com)**

---

VI TELEFILTER reserves the right to make changes to the product(s) and/or information contained herein without notice. No liability is assumed as a result of their use or application. No rights under any patent accompany the sale of any such product(s) or information.