



Helping Customers Innovate, Improve & Grow



Description

Vectron's VX-705 Voltage Controlled Crystal Oscillator (VCXO) is a quartz stabilized square wave generator with a CMOS output. The VX-705 uses fundamental crystals resulting in low jitter performance and a monolithic IC which improves reliability and reduces cost.

Features

- CMOS output VCXO
- Output Frequencies from 77.76 MHz to 160 MHz
- 3.3 V Operation
- Fundamental Crystal Design with Low Jitter Performance
- Output Disable Feature
- Excellent 20ppm Temperature Stability,
- 0/70°C or -40/85°C Operating Temperature
- Small Industry Standard Package, 5.0x7.0x1.8mm
- Product is free of lead and compliant to EC RoHS Directive

Applications

- SONET/SDH/DWDM
- Ethernet, SyncyE, GE
- xDSL, PCMIA
- Digital Video
- Broadband Access
- Base Stations, Picocells

Block Diagram

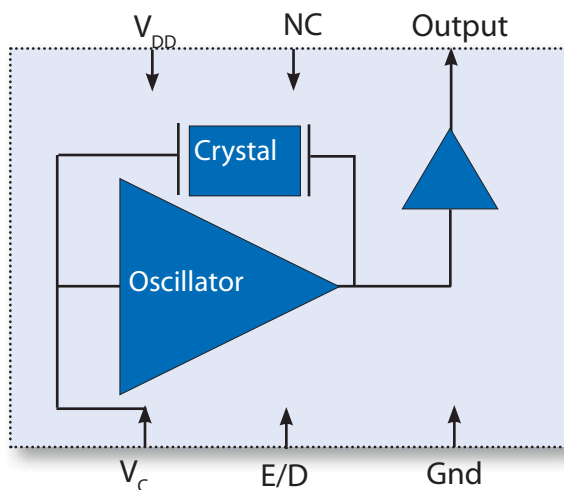

Performance Specifications

Table 1. Electrical Performance

Parameter	Symbol	Min	Typical	Maximum	Units
Supply					
Voltage ¹	V_{DD}	3.135	3.3	3.465	V
Current ²	I_{DD}			40	mA
Frequency					
Nominal Frequency ³	f_N	77.76		160.00	MHz
Absolute Pull Range ^{2,6} , <i>ordering option</i>	APR	$\pm 50, \pm 80$			ppm
Linearity ²	Lin		5		%
Gain Transfer ²	K_V	+80			ppm/V
Temperature Stability	f_{STAB}		± 20		ppm
Outputs					
Output Logic Levels ² Output Logic High Output Logic Low	V_{OH} V_{OL}	$0.9 * V_{DD}$		$0.1 * V_{DD}$	V
Load	I_{OUT}			15	pF
Rise Time ^{2,4}	t_R			5	ns
Fall Time ^{2,4}	t_F			5	ns
Symmetry ²	SYM	45	50	55	%
Period Jitter, RMS ^{5,7} (155.520 MHz)	ϕ_J		3.0		ps
Period Jitter, pk-pk ^{5,7} (155.520MHz)	ϕ_J		23		ps
Phase Noise ⁸ 10Hz 100Hz 1kHz 10kHz 100kHz 1MHz 10MHz			-57 -87 -118 -146 -154 -154 -154		dBc/Hz
Control Voltage					
Control Voltage Range for Pull Range	V_C	0.3		3.0	V
Control Voltage Input Impedance	Z_{IN}		100		K Ω
Control Voltage Modulation BW	BW	10			kHz
Output Enable/Disable ⁹ Output Enabled Output Disabled	V_{IH} V_{IL}	$0.9 * V_{DD}$		$0.1 * V_{DD}$	V
Start-Up Time	T_S			10	ms
Operating Temp, Ordering Option	T_{OP}	0/70, -20/70, or -40/85			°C
Package Size		5.0 x 7.0 x 1.8			mm

- 1] The power supply should have by-pass capacitors as close to the supply and to ground as possible, for examples 0.1 and 0.01uF
- 2] Parameters are tested with production test circuit below (Fig 1).
- 3] See Standard Frequencies and Ordering Information tables for more specific information
- 4] Measured from 20% to 80% of a full output swing (Fig 2).
- 5] Not tested in production, guaranteed by design, verified at qualification.
- 6] Tested with $V_C = 0.3V$ to $3.0V$ unless otherwise stated in part description
- 7] Broadband Period Jitter measured using Wavecrest SIA3300C, 90K samples.
- 8] Phase Noise is measured with an Agilent E5052A.
- 9] The Output is Enabled if the Enable/Disable is left open.

Test Circuit

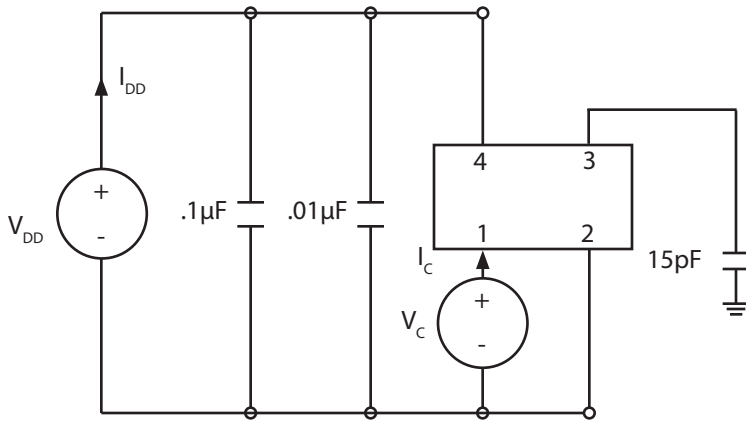

Fig 1: Test Circuit

Waveform

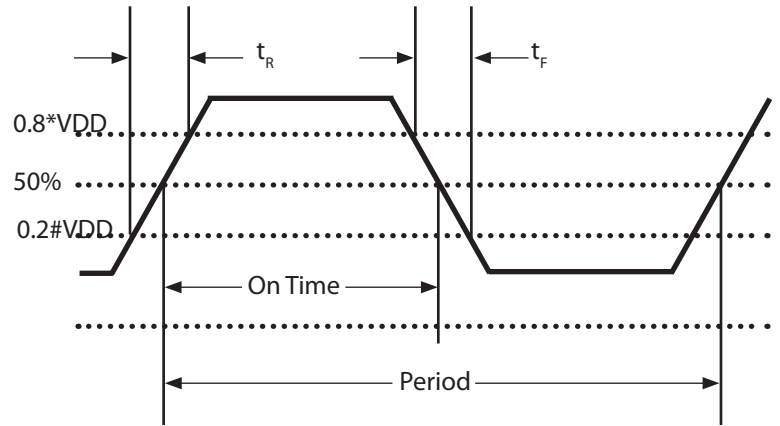

Fig 2: Waveform

Table 2. Absolute Maximum Ratings

Parameter	Symbol	Ratings	Unit
Power Supply	V_{DD}	0 to 6	V
Voltage Control Range	V_C	0 to V_{CC}	V
Storage Temperature	TS	-55 to 125	°C
Soldering Temp/Time	T_{LS}	260 / 20	°C / sec

Stresses in excess of the absolute maximum ratings can permanently damage the device. Functional operation is not implied at these or any other conditions in excess of conditions represented in the operational sections of this datasheet. Exposure to absolute maximum ratings for extended periods may adversely affect device reliability. Permanent damage is also possible if OD or Vc is applied before Vcc.

Typical Phase Noise

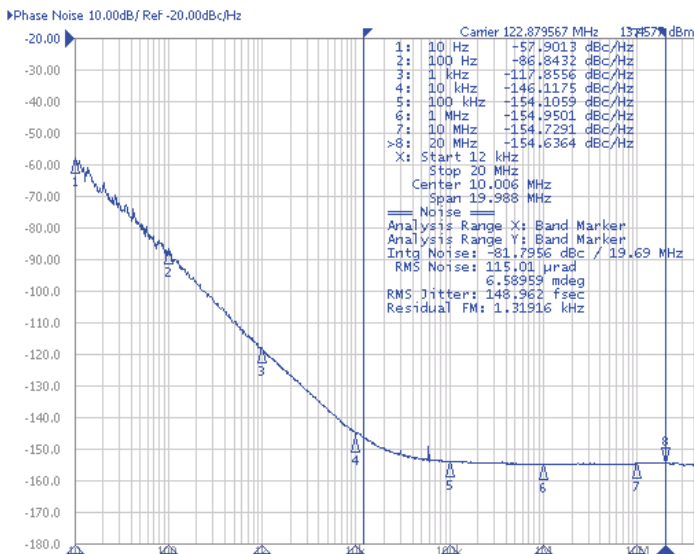

Typical Gain

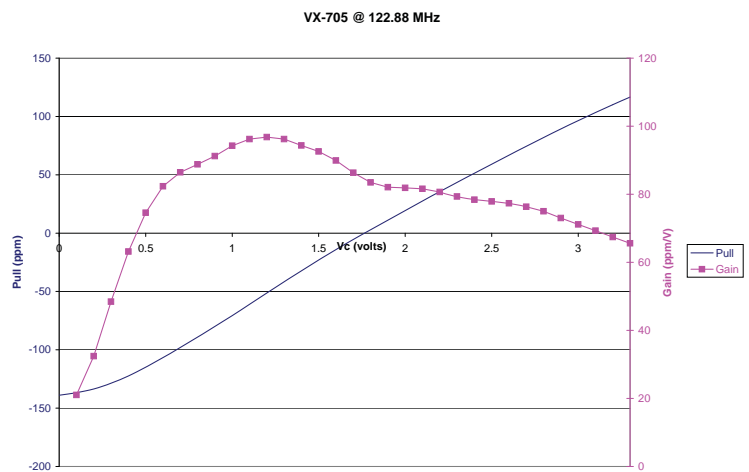

Reliability

VI qualification includes aging at various extreme temperatures, shock and vibration, temperature cycling, and IR reflow simulation. The VX-705 family is capable of meeting the following qualification tests:

Table 3. Environmental Compliance

Parameter	Conditions
Mechanical Shock	MIL-STD-883, Method 2002
Mechanical Vibration	MIL-STD-883, Method 2007
Solderability	MIL-STD-883, Method 2003
Gross and Fine Leak	MIL-STD-883, Method 1014
Resistance to Solvents	MIL-STD-883, Method 2015
Moisture Sensitivity Level	MSL 1
Contact Pads	Gold over Nickel

Handling Precautions

Although ESD protection circuitry has been designed into the VX-705 proper precautions should be taken when handling and mounting. VI employs a human body model (HBM) and a charged device model (CDM) for ESD susceptibility testing and design protection evaluation.

Table 4. ESD Ratings

Model	Minimum	Conditions
Human Body Model	500V	MIL-STD-883, Method 3015
Charged Device Model	500V	JESD22-C101

Table 5. Reflow Profile

Parameter	Symbol	Value
PreHeat Time Ts-min Ts-max	t_s	60 sec Min, 180 sec Max 150°C 200°C
Ramp Up	R_{UP}	3 °C/sec Max
Time Above 217 °C	t_L	60 sec Min, 150 sec Max
Time To Peak Temperature	T_{AMB-P}	480 sec Max

Solderprofile:

The device is qualified to meet the JEDEC standard for Pb-Free assembly. The temperatures and time intervals listed are based on the Pb-Free small body requirements. The VX-705 device is hermetically sealed so an aqueous wash is not an issue.

Termination Plating:
Electroless Gold Plate over Nickel Plate

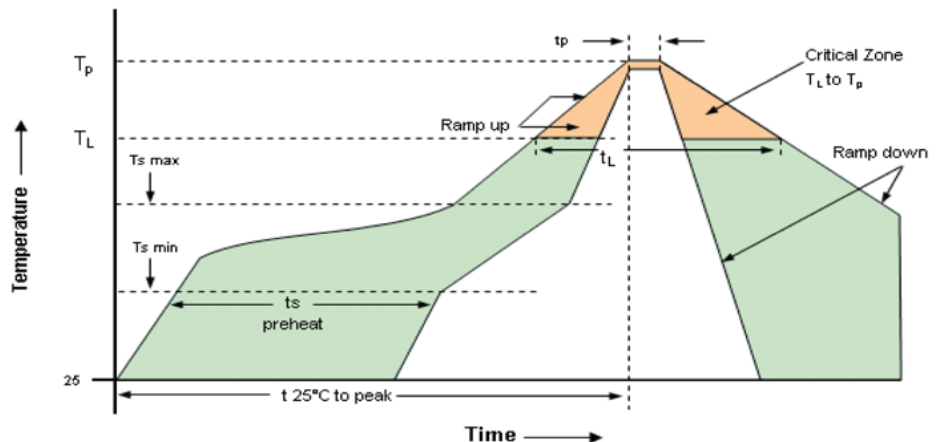

Outline Drawing & Pad Layout

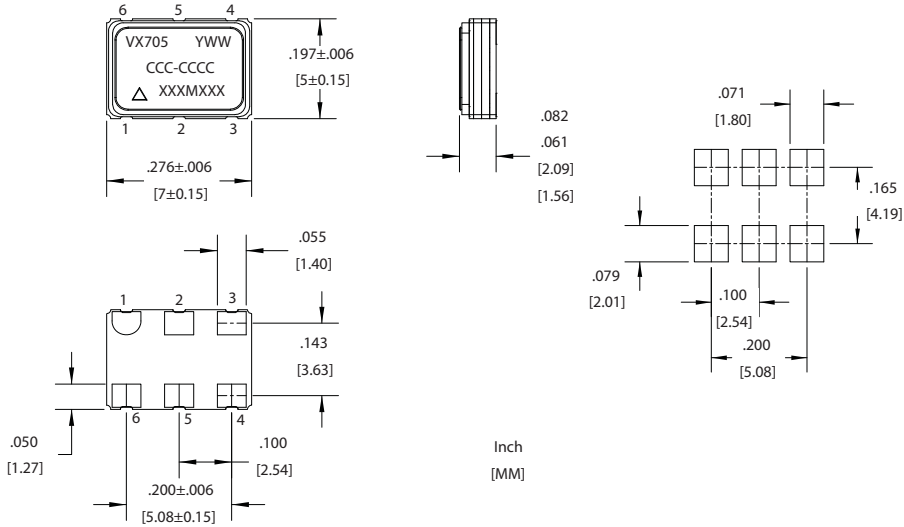

Table 6. Pin Out

Pin	Symbol	Function
1	V_C	VCXO Control Voltage
2	E/D	Enable Disable
3	GND	Case and Electrical Ground
4	Output	Output
5	N/C	No Connect
6	V_{DD}	Power Supply Voltage

Tape & Reel (EIA-481-2-A)

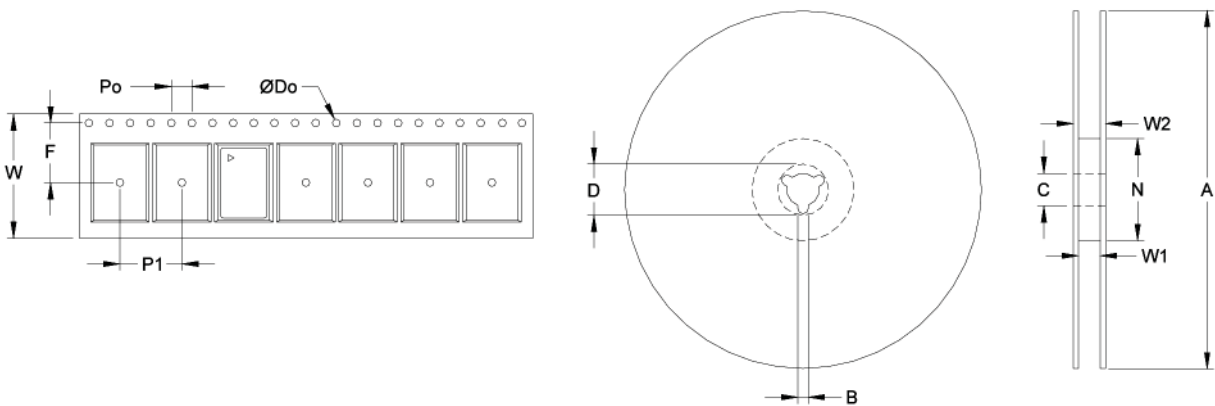

Table 7. Tape and Reel Information

Tape Dimensions (mm)						Reel Dimensions (mm)							
Dimension	W	F	Do	Po	P1	A	B	C	D	N	W1	W2	# Per Reel
Tolerance	Typ	Typ	Typ	Typ	Typ	Typ	Min	Typ	Min	Min	Typ	Max	
VX-705	12	5.5	1.5	4	8	178	1.78	13	20.6	55	12.4	22.4	500

Table 8. Standard Output Frequencies (MHz)							
89.60000	93.31200	100.00000	122.88000	125.00000	127.79520	148.50000	155.52000
156.25000							

Ordering Information

VX-705- E A T - K X A N- 122M880000

Product

VCXO, 5x7 Package

Voltage Options

E: +3.3 Vdc

Output

A: CMOS

Temp Range

T: 0/70°C

J: -20/70°C

E: -40/85°C

Frequency in MHz

Other (Future Use)

N: Standard

Enable/Disable

A: Enable High

Stability

X: Standard

E: ±20ppm Temperature

Absolute Pull Range

K: ±50ppm

P: ±80ppm

**Note: not all combination of options are available.
Other specifications may be available upon request.*

Example: VX-705-EAT-KANN-122M880000

For Additional Information, Please Contact

USA:

Vectron International
267 Lowell Road
Hudson, NH 03051
Tel: 1.888.328.7661
Fax: 1.888.329.8328

Europe:

Vectron International
Landstrasse, D-74924
Neckarbischofsheim, Germany
Tel: +49 (0) 3328.4784.17
Fax: +49 (0) 3328.4784.30

Asia:

Vectron International
1F-2F, No 8 Workshop, No 308 Fenju Road
WaiGaoQiao Free Trade Zone
Pudong, Shanghai, China 200131
Tel: 86.21.5048.0777
Fax: 86.21.5048.1391

Disclaimer

Vectron International reserves the right to make changes to the product(s) and or information contained herein without notice. No liability is assumed as a result of their use or application. No rights under any patent accompany the sale of any such product(s) or information.

Revision History

Date	Approved	Description
10Jan2009	FB	Release.
06Jan2010	BW	Added ± 20 ppm temperature stability ordering option to 13th product code field. ENABLE ordering option moved from 13th to 14th product code field. -20/70° operating temperature ordering option added.